

Connect  
with  
center punch

# Instruction Manual

# UNO 30

## Hook connector

Art.-No. K120

<p><b>1. Drilling</b></p>	<p><b>2. To clip on</b></p>
<p><b>3. Screwing</b></p> <p>TORX 10</p> <p>3x PH screw 3x13 <math>t \geq 20</math> mm</p>	<p><b>4. Copy</b></p>
<p><b>5. Screwing</b></p> <p>TORX 25</p> <p>KNAPP® CS screw 5x50 with washer</p>	<p><b>6. To connect</b></p> <p>Warning! Activate the Locking clip by to bow out the metal.</p> <p>"Klick"</p> <p><math>\geq 13</math></p> <p>OK</p>

This drawing is the exclusive property of Knapp GmbH.

© Knapp GmbH. All measures in mm - Errors excepted. VERSION 03 01.12.2014

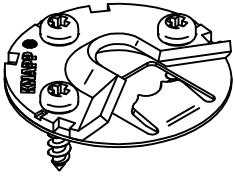

Art.-No. K120

Connect  
with  
drilling jig

Instruction Manual

UNO 30

Hook connector

**1. Adjust**

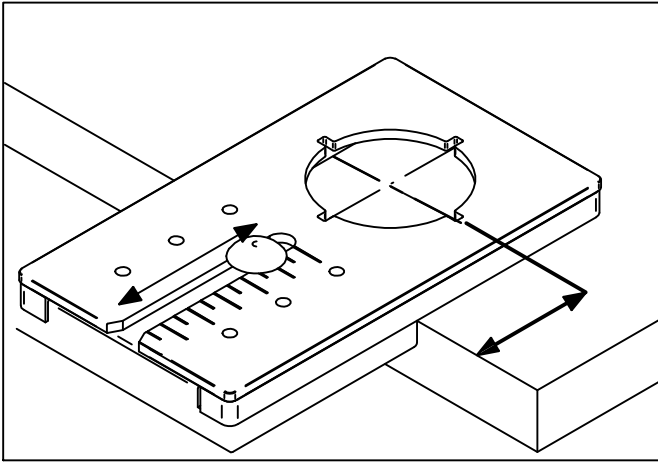

**2. Drilling**

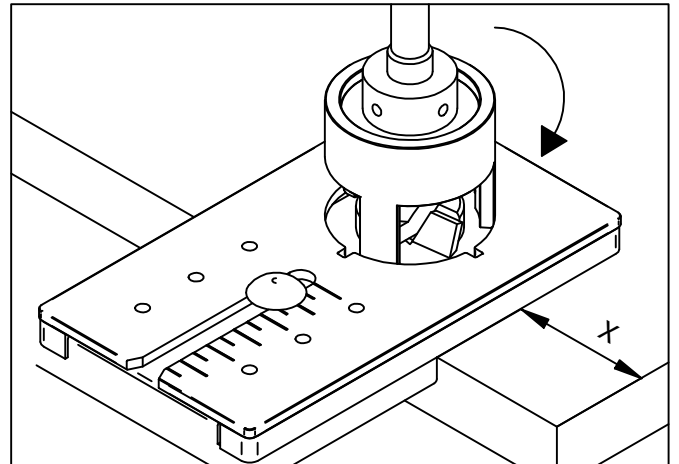

**3. Screwing**

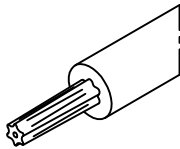

TORX 10



3x PH screw 3x13  
t ≥ 20 mm

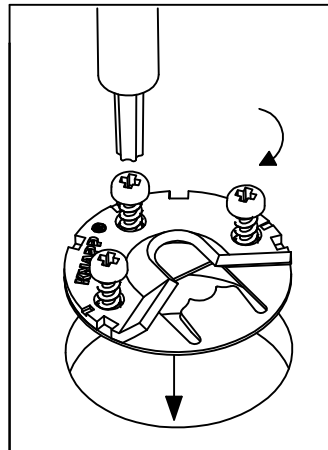

**4. Copy**

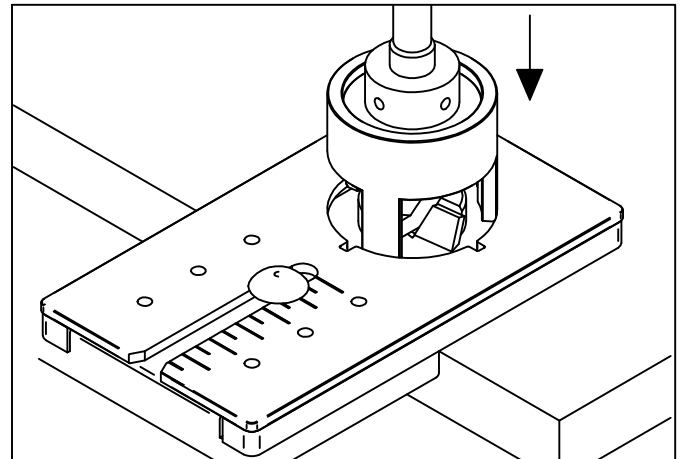

**5. Screwing**

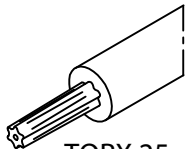

TORX 25

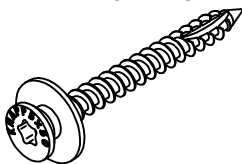

KNAPP® CS screw 5x50 with  
washer

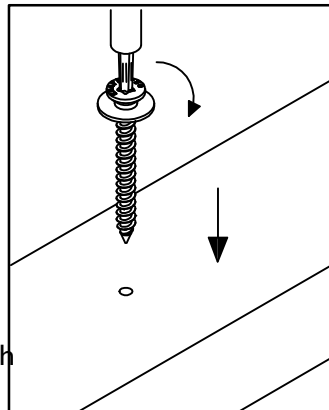

**6. To connect**

Warning! Activate the Locking clip by to  
bow out the metal.

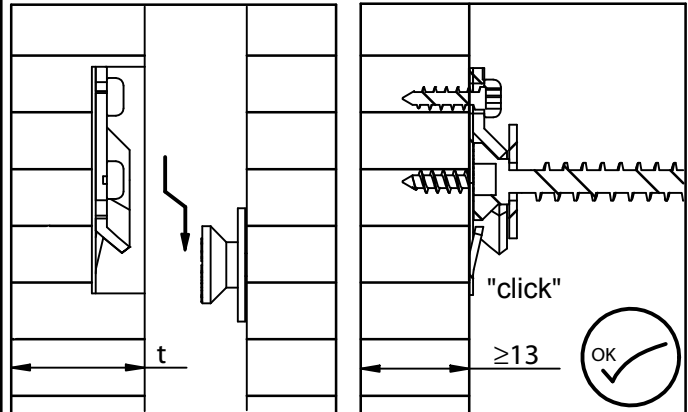

This drawing is the exclusive property of Knapp GmbH.

© Knapp GmbH. All measures in mm - Errors excepted. VERSION 03 01.12.2014

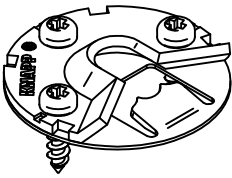

# Mise en oeuvre avec pointeur

Notice de montage

# UNO 30

Réf. K120

Connecteur d'accroche

## 1. Percer

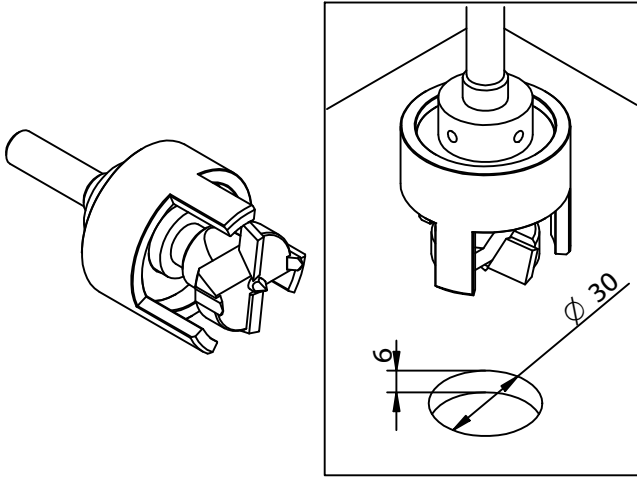

## 2. Emboiter

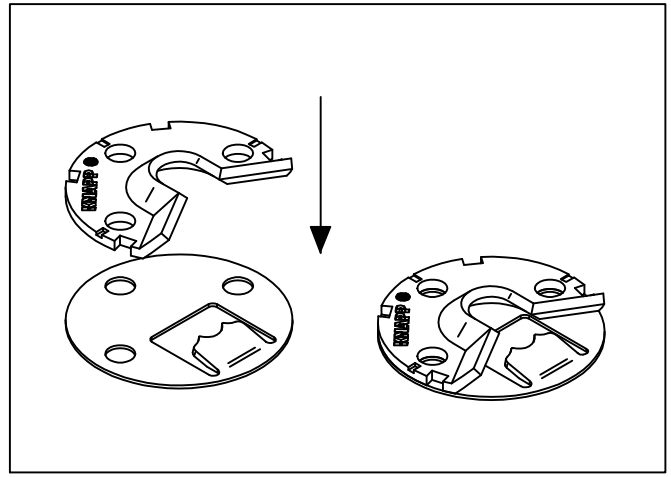

## 3. Visser

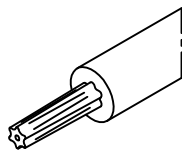

TORX 10



3 vis 3x13 tête ronde  
t  $\geq 20$  mm

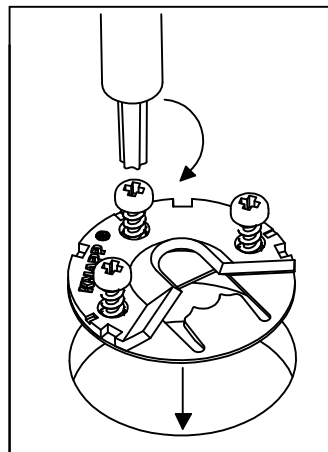

## 4. Pointer

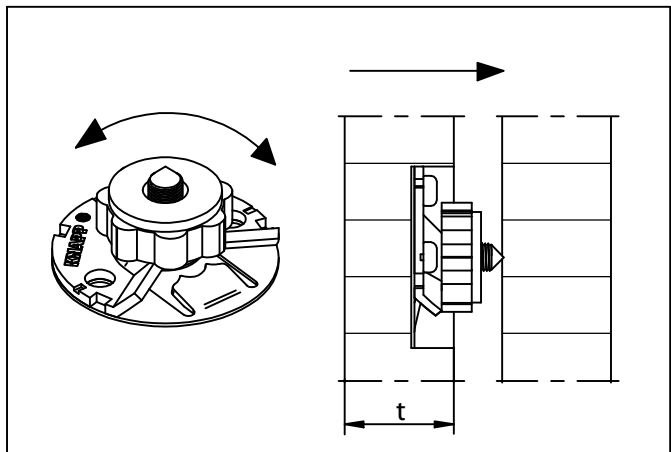

## 5. Visser

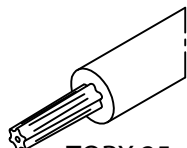

TORX 25

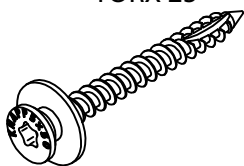

Vis KNAPP® SK 5x50 avec  
rondelle de butée

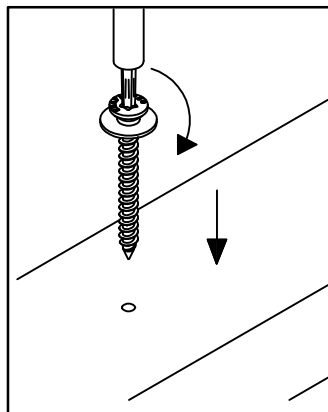

## 6. Accrocher

Attention ! Activer le verrouillage en  
dépliant la languette de la goupille

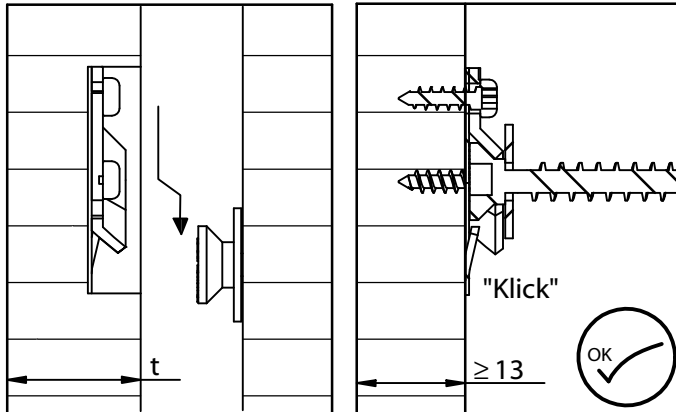

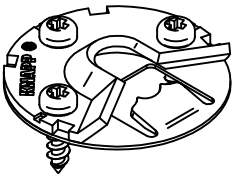

# Mise en oeuvre avec gabarit de perçage

# Notice de montage

# UNO 30

Réf. K120

## Connecteur d'accroche

### 1. Régler le gabarit

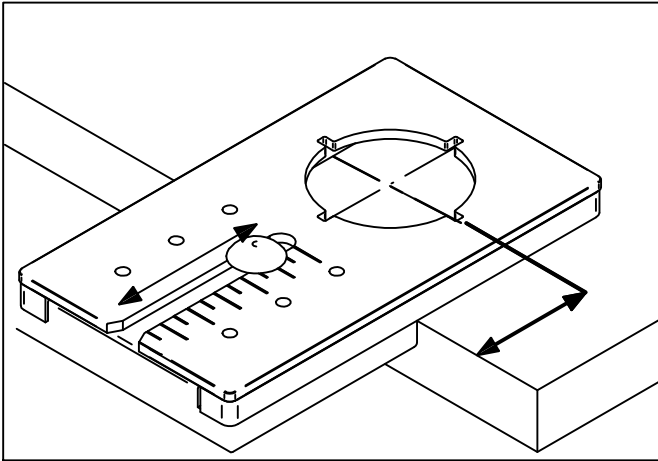

### 2. Percer

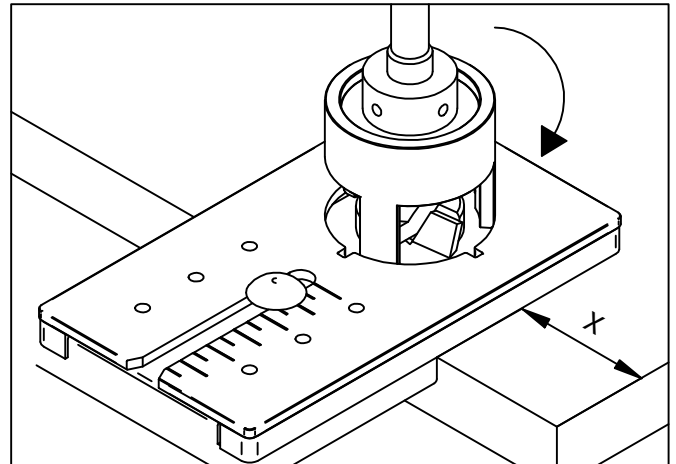

### 3. Visser

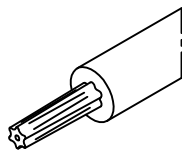

TORX 10



3 vis 3x13 tête ronde  
t ≥ 20 mm

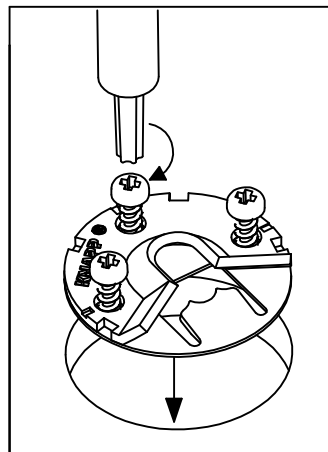

### 4. Pointer

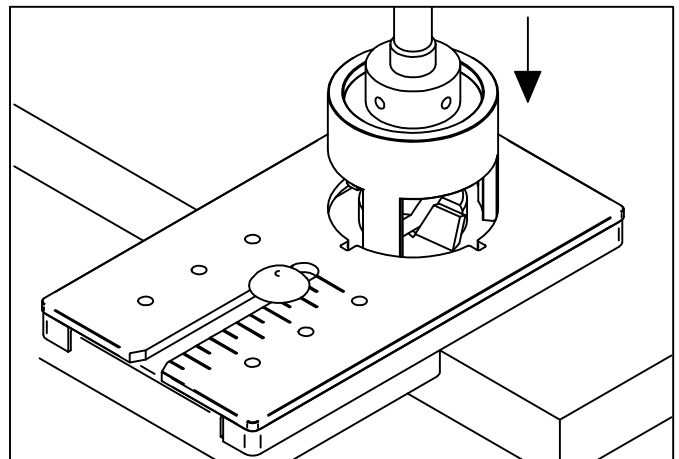

### 5. Visser

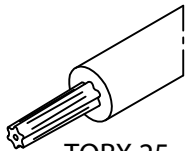

TORX 25

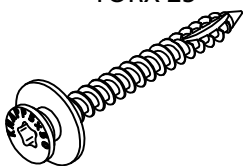

Vis KNAPP® SK 5x50 avec  
rondelle de butée

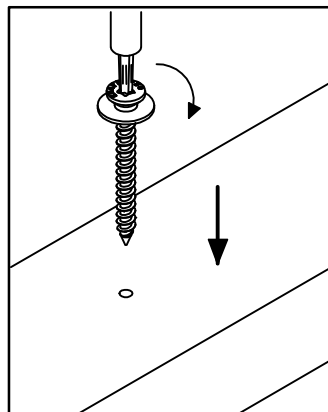

### 6. Accrocher

Attention ! Activer le verrouillage en  
dépliant la languette de la goupille

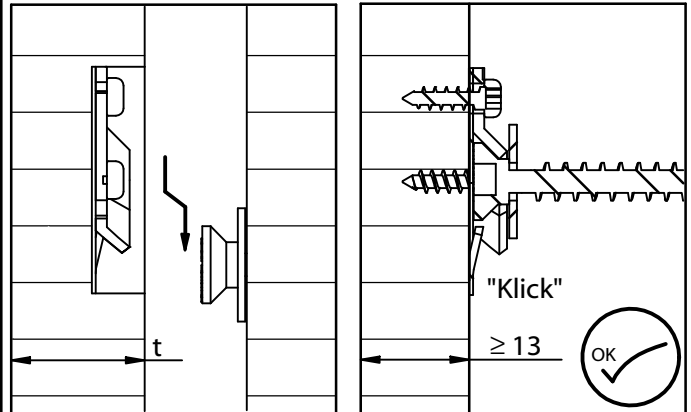

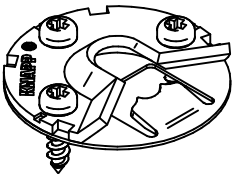

# Montage mit Körner

# Montageanleitung

# UNO 30

# Einhängeverbinder

Art.-Nr. K120

## 1. Bohren

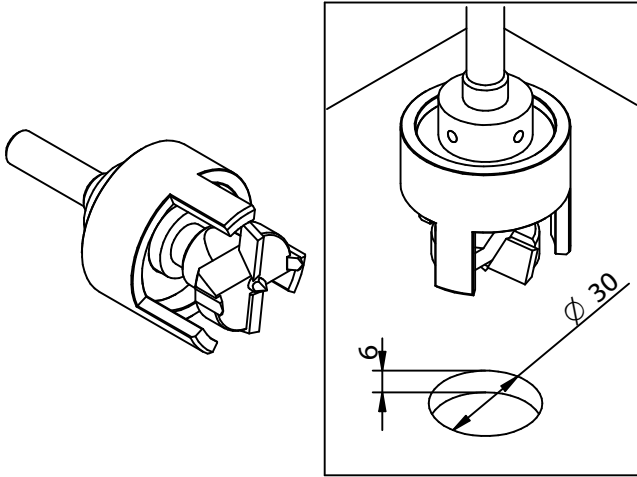

## 2. Aufstecken

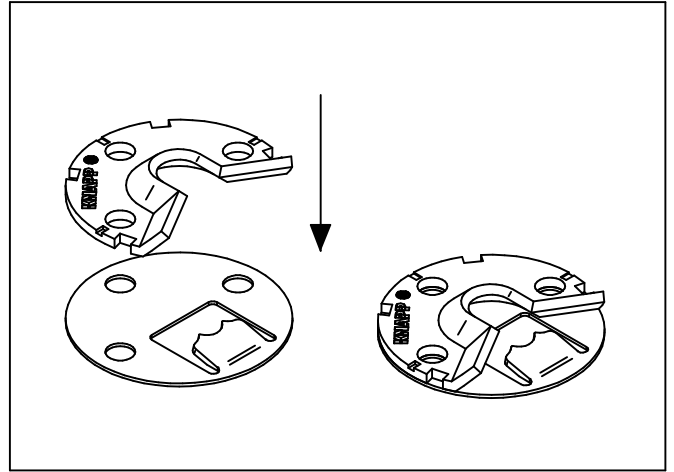

## 3. Verschrauben

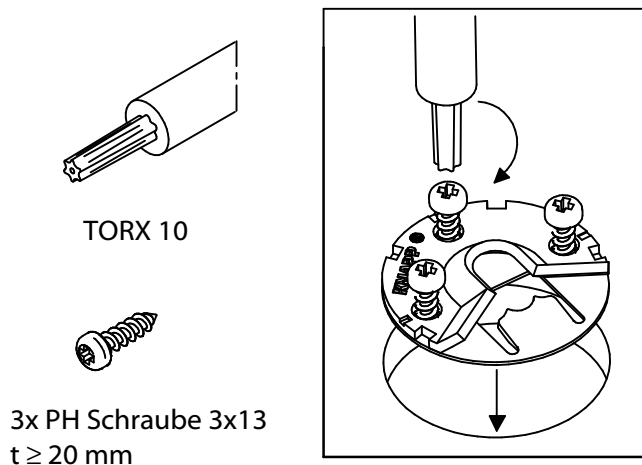

## 4. Markieren

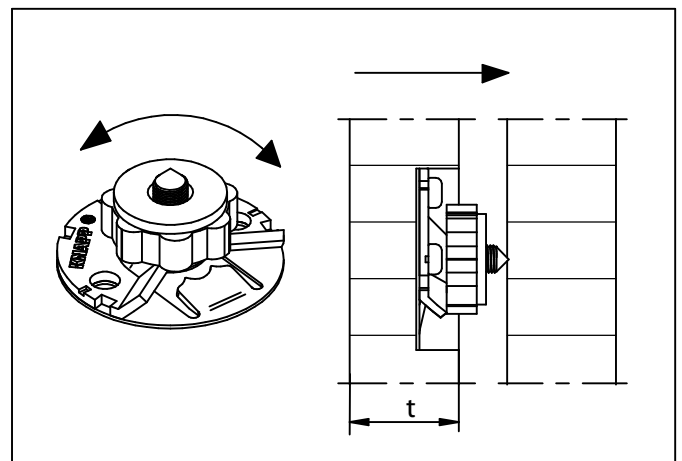

## 5. Verschrauben

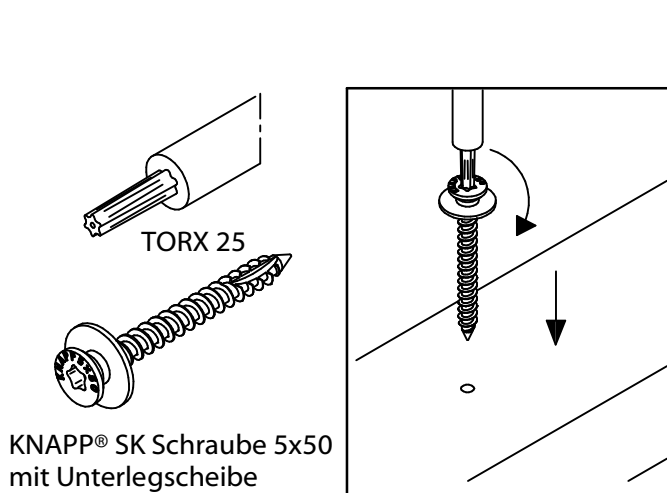

## 6. Einhängen

Achtung! Sperrlasche durch ausbiegen aktivieren

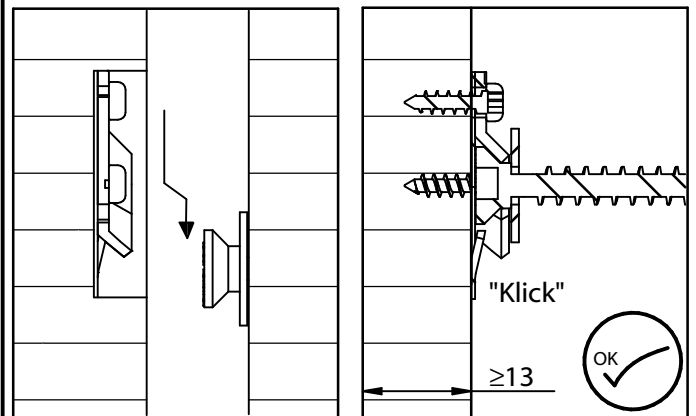

Diese Zeichnung ist Eigentum der Knapp GmbH.

© Knapp GmbH. Alle Maße in mm - Irrtümer, Druckfehler und Änderungen vorbehalten. VERSION 03 01.12.2014

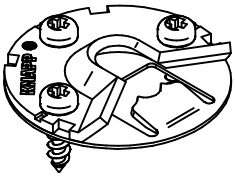

# Montage mit Bohrschablone

# Montageanleitung UNO 30 Einhängeverbinder

Art.-Nr. K120

## 1. Einstellen

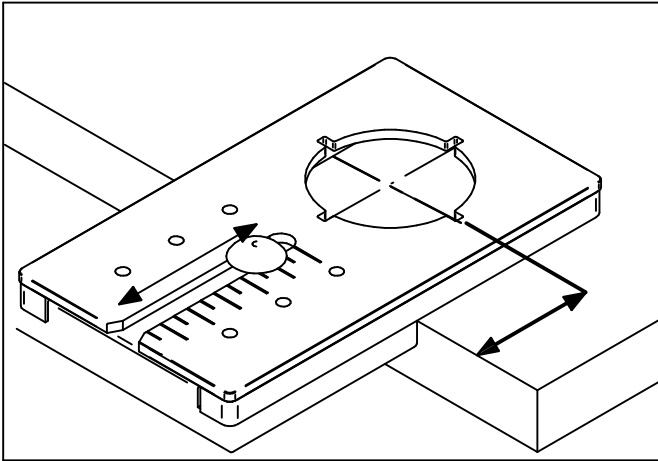

## 2. Bohren

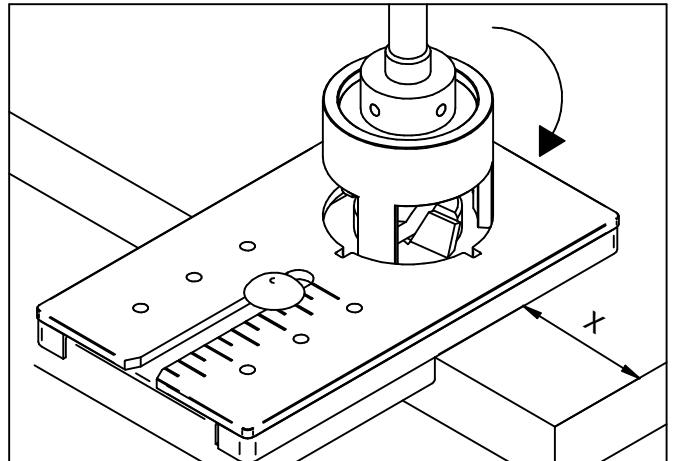

## 3. Verschrauben

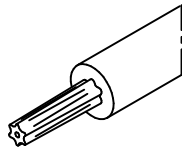

TORX 10



3x PH Schraube 3x13  
t ≥ 20 mm

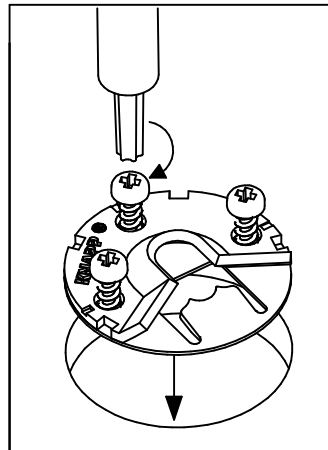

## 4. Markieren

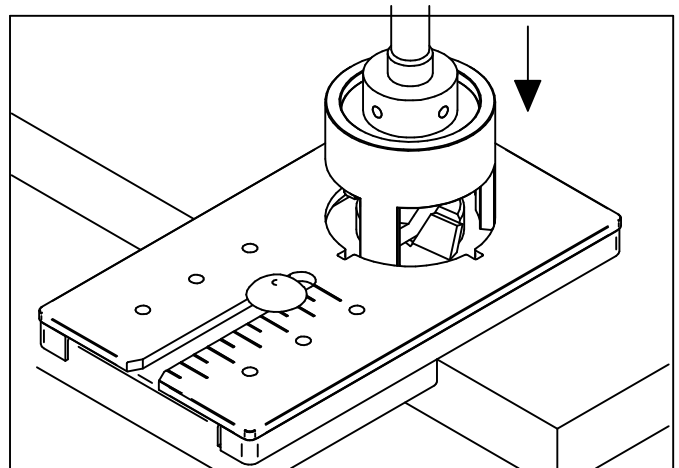

## 5. Verschrauben



TORX 25

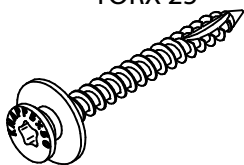

KNAPP® SK Schraube 5x50  
mit Unterlegscheibe

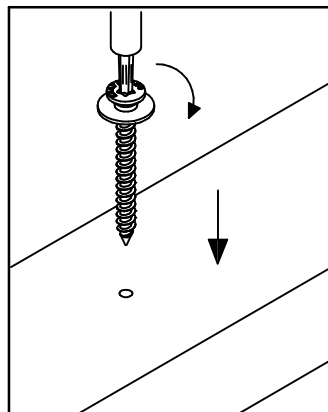

## 6. Einhängen

Achtung! Sperrlasche durch ausbiegen aktivieren

